

# JOLLY JUMP

- ✓ 6 Different Games
- ✓ Available with 8 or 12 arms



GROUP

# JOLLY JUMP

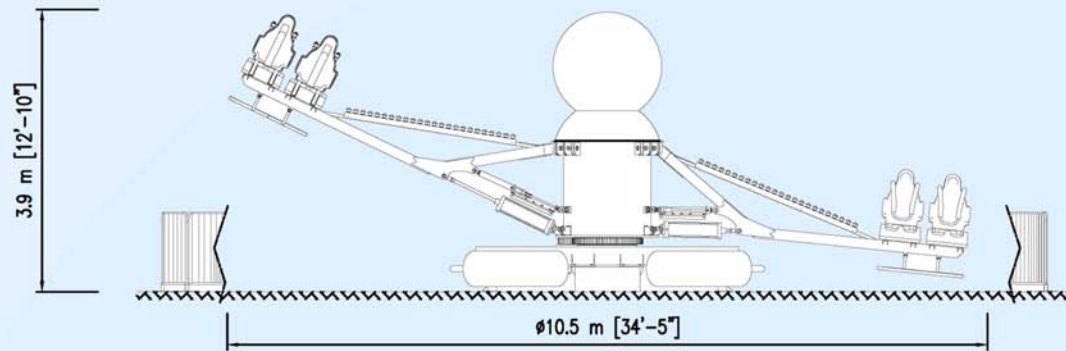

ELECTRICAL INFORMATION			LOAD INFORMATION		
1	MOTIVE POWER	53 kW	1	TOTAL RIDE WEIGHT	10000 Kg.
2	LIGHT POWER	6.5 kW	2	SUPPORT ON THE FLOOR:	Nr. 12
3	OTHER POWER	-	3	STATIC LOAD	834 Kg.
4	TOTAL POWER	59.5 kW	4	DYNAM C LOAD	1410 Kg.

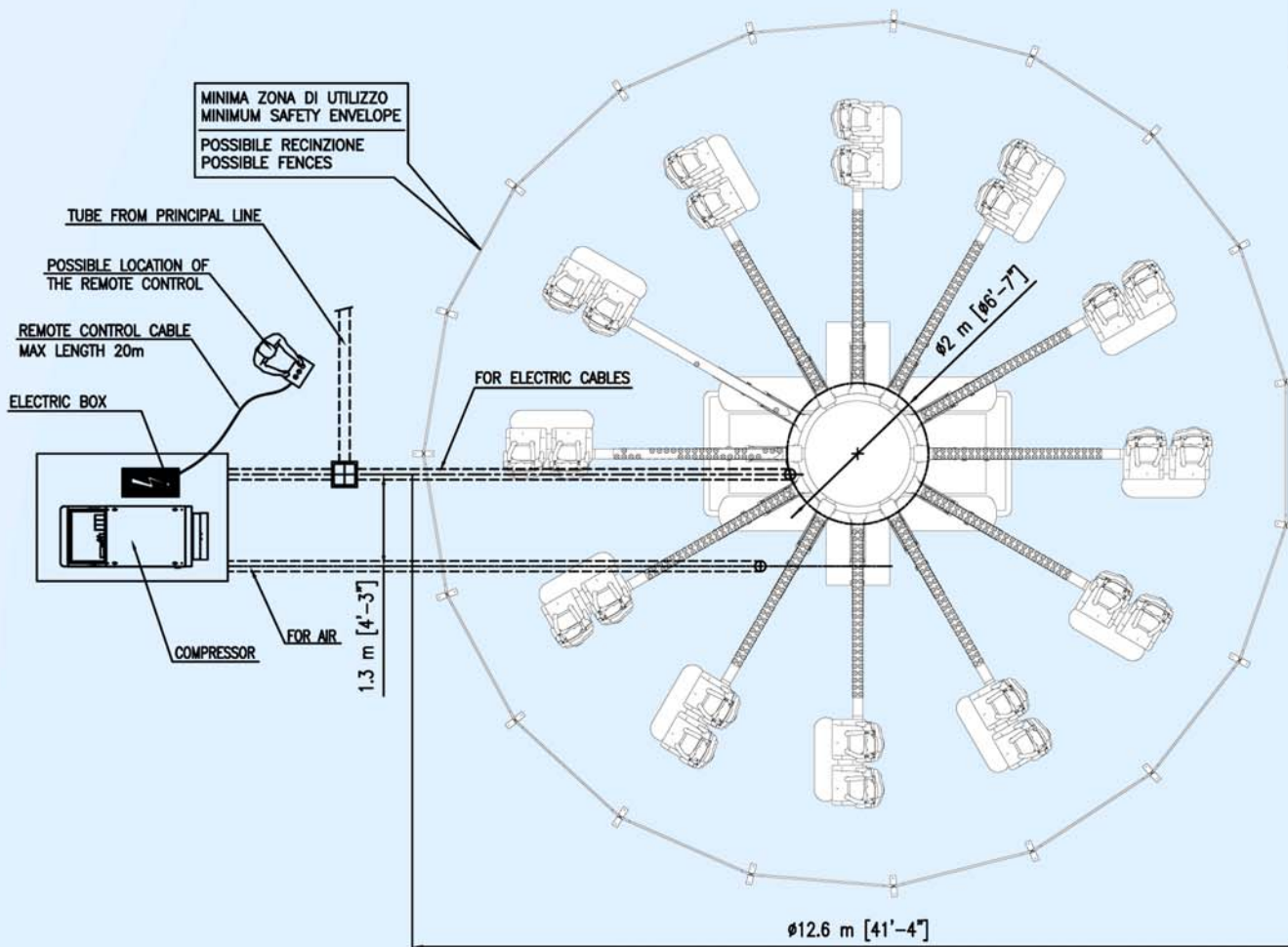

## DATI TECNICI - TECHNICAL DATA

Dimensione di base zona di lavoro Base dimensions operation area	3.9 x Ø12.6 m 12'10" x Ø41' 4"
Veicoli Vehicles	12
Numero di Posti Number of seating	24
Voltaggio Voltage	380 / 220 V (50/60Hz)
Direzione di lavoro Direction of travel	Oraria Clockwise
N°giri al m'nuto arm RPM	8 RPM max



### S.B.F. srl

Via Dei Placco, 217 int.1  
35040 Casale di Scodosia (PD) ITALY  
Tel: +39-0429-847098  
Fax: +39-0429-878287  
E-mail: sbf@sbfrides.com  
www.sbfrides.com

### VISA International srl

Via Dell'Apprendistato, 2  
35044 Montagnana (PD) ITALY  
Tel: +39-0429-804622  
Fax: +39-0429-81699  
E-mail: visa@visarides.it  
www.visarides.it